

# IPA 1800

## Ink Jet Marking System

A product of *Nortek Automation, Inc.*



Nortek's inkjet marking system is fast and flexible. New products can be set up within minutes. This system can be used in-line, connected to a network database, or off-line in batch mode.

### ***NORTEK AUTOMATION INC.***

Providing Solutions Through Automation Since 1985

#### **WORLD HEADQUARTERS**

15632 Producer Lane, Huntington Beach, CA 92649 USA

Phone (714)895-8590\*Fax (714)895-8039

[www.nortekautomation.com](http://www.nortekautomation.com)

Copyright ©1996-2001 Nortek Automation, Inc. All rights reserved.

#### **SALES & SERVICE**

Texas, Illinois, California, U.K., Switzerland, Taiwan, Japan, & Hong Kong

## Features

- Versatile:** Mark on demand  
X-Y positioning of printhead  
Automatic serialization  
Barcodes, 2D, Graphics  
Multilevel passwords  
Up to 18" x 20" product
- Productive:** Up to 1800 characters/second  
Simple set-up  
Open design for easy access  
Automatic error recovery



## Options

- Board Stacker and De-Stacker
- Custom Product Handling
- X-out Reader
- Barcode Scanner
- Network Interface

## Technical Specifications

- Conveyor:** SMEMA compatible  
Width adjustment 1"-18"  
Up to 48 ft. per minute
- Controls:** Windows-based PC

# FACILITY REQUIREMENTS

## IPA 1800

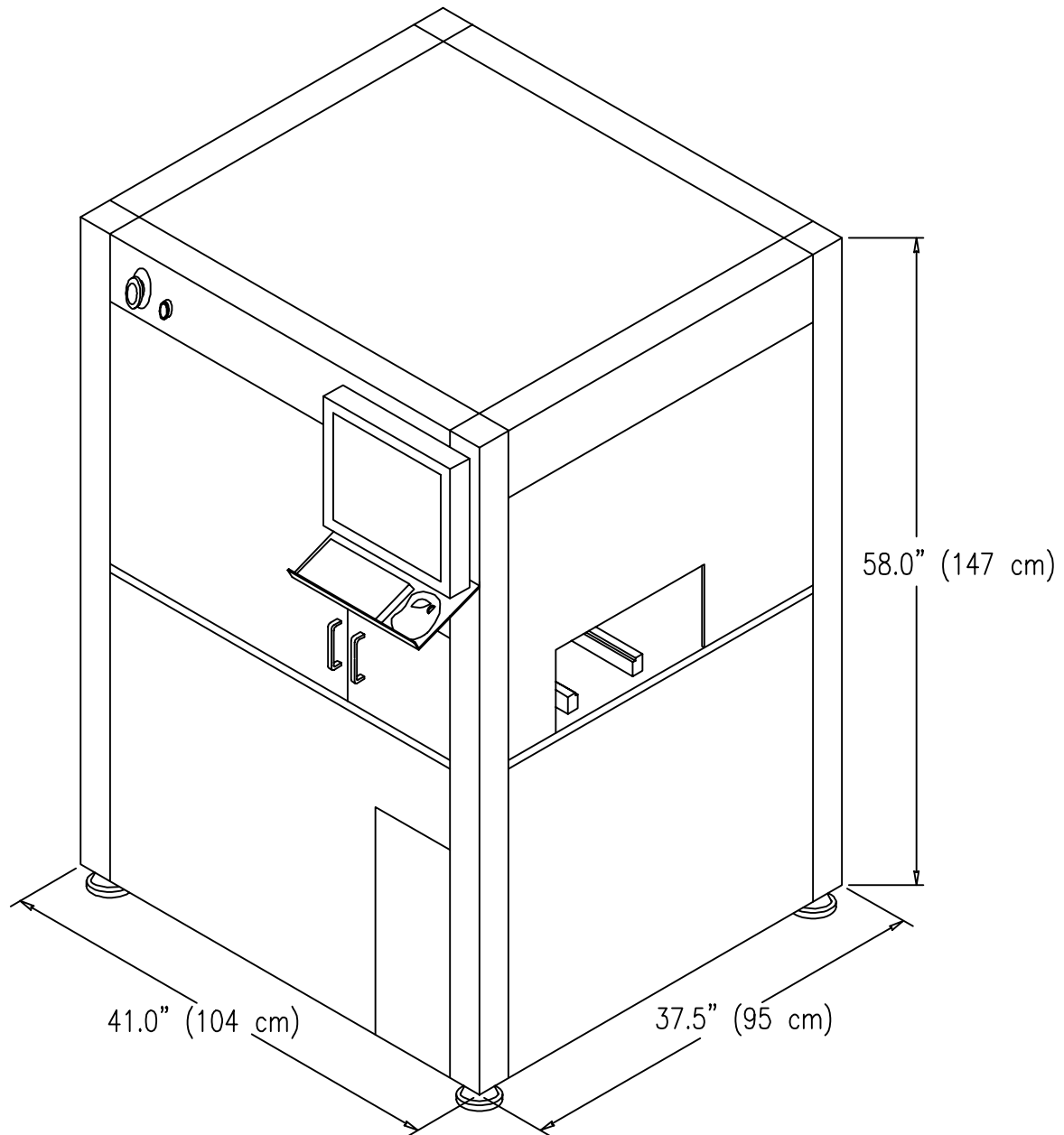

**Power:** 110 VAC, 10 AMP, Single Phase

**Air Fitting:** 1/4" Plug, Industrial Design  
Quick Disconnect  
(MIL-C-4109)

**Air Consumption:** 15 SCFM (433 Nl/min)  
Clean, dry air @ 100 PSI  
(6.9 Bar)

**Weight:** 500 pounds, 227 kg.

***NORTEK AUTOMATION, INC.***  
[www.nortekautomation.com](http://www.nortekautomation.com)

Copyright (c) 2001  
All Rights Reserved