

# Comet 3200

## PC-Card Labeler

A product of *Nortek Automation, Inc.*

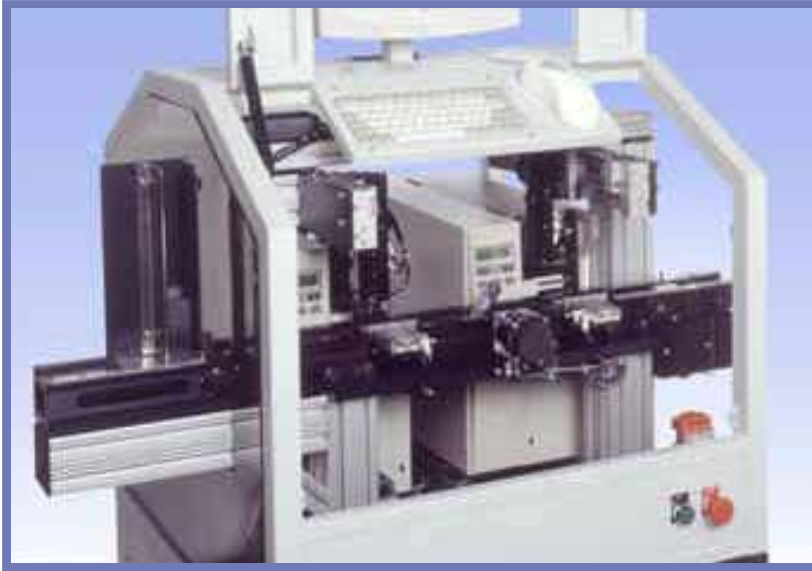

FLASH \* ATA \* PCMCIA

The Comet 3200 can be configured for any type of PC-Card or Compact Flash. The system can be fed via operator, magazine, or in-line conveyor. Product is automatically inverted for second label application. Labels can be preprinted or printed on-demand.

### **NORTEK AUTOMATION INC.**

Providing Solutions Through Automation Since 1985

#### **WORLD HEADQUARTERS**

15632 Producer Lane, Huntington Beach, CA 92649 USA

Phone (714)895-8590\*Fax (714)895-8039

[www.nortekautomation.com](http://www.nortekautomation.com)

Copyright ©1996-2001 Nortek Automation, Inc. All rights reserved.

#### **SALES & SERVICE**

Texas, Illinois, California, U.K., Switzerland, Taiwan, Japan, & Hong Kong

## Features

**Versatile:** Print on demand 600 dpi  
Adjustable tamp force  
Automatic serialization  
Multiple label sizes  
Barcodes, 2D, Graphics  
Multilevel passwords  
Dual-sided labeling  
Batch or In-Line

**Productive:** One second/label capability  
Simple set-up  
Open design for easy access  
Automatic error recovery



Patent Pending

## Technical Specifications

**Throughput:** Up to 3,600 labels/hour

#### **Label Placement**

**Accuracy:** +/- .010" (.254mm)

# FACILITY REQUIREMENTS

## COMET 3200

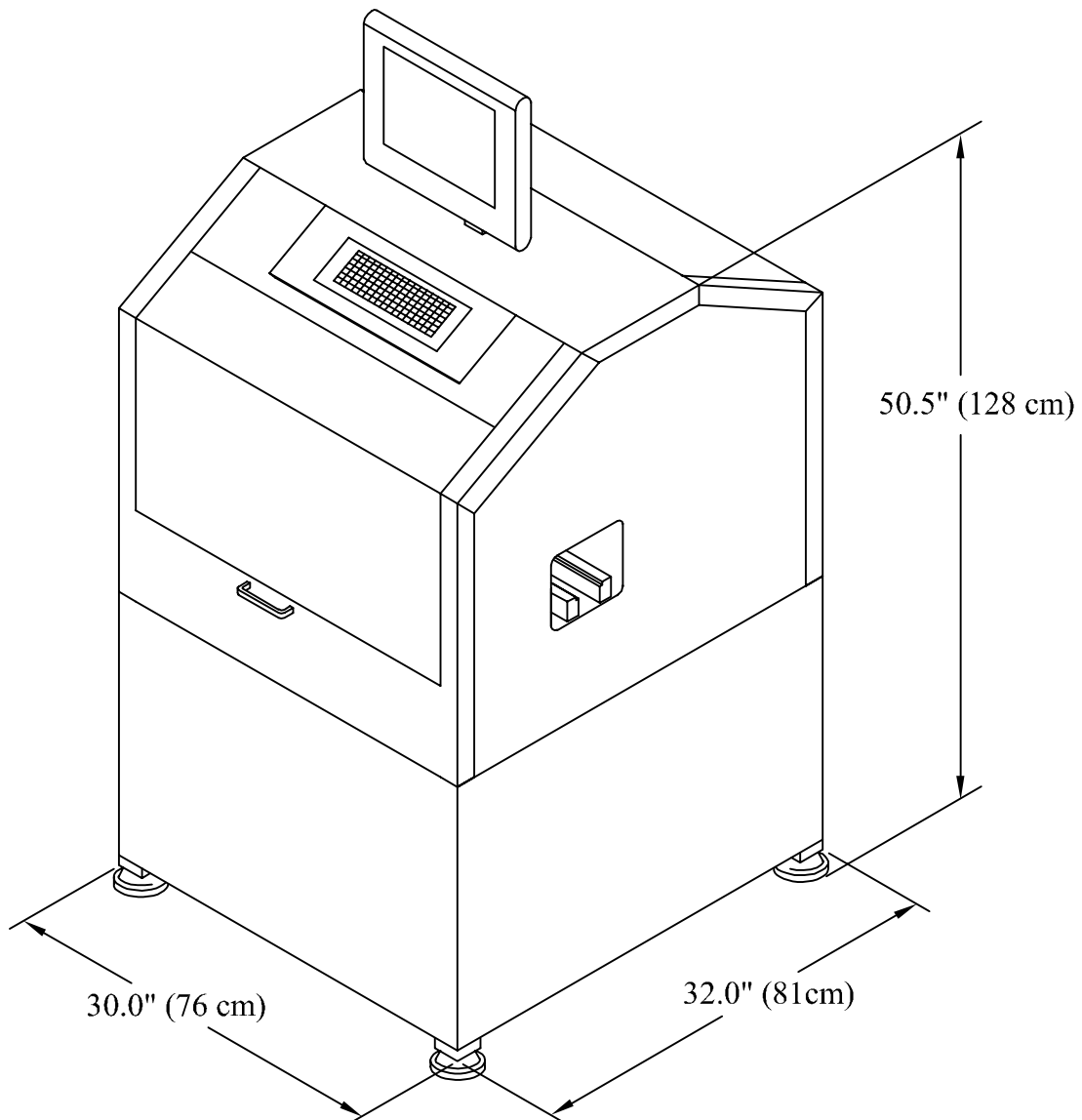

**Power:** 220 VAC, 5 AMP, Single Phase

**Air Fitting:** 1/4" Plug, Industrial Design  
Quick Disconnect  
(MIL-C-4109)

**Air Consumption:** 10 SCFM (285 Nl/min)  
Clean, dry air @ 100 PSI  
(6.9 Bar)

**Weight:** 400 pounds, 182 kg.

**NORTEK AUTOMATION, INC.**  
[www.nortekautomation.com](http://www.nortekautomation.com)

Copyright (c) 2001  
All Rights Reserved