

Equinox 3000 Manual-Feed Labeler

A product of *Nortek Automation, Inc.*



NORTEK AUTOMATION INC.

Providing Solutions Through Automation Since 1985

WORLD HEADQUARTERS

15632 Producer Lane, Huntington Beach, CA 92649 USA

Phone (714)895-8590*Fax (714)895-8039

www.nortekautomation.com

Copyright ©1996-2001 Nortek Automation, Inc. All rights reserved.

SALES & SERVICE

Texas, Illinois, California, U.K., Switzerland, Taiwan, Japan, & Hong Kong

Features

Versatile: Print on demand 600 dpi
Adjustable tamp force
Automatic serialization
Barcodes, 2D, Graphics
Multilevel passwords
Adjustable tamp force

Productive: Three seconds per label
Simple set-up
Open design for easy access
Automatic error recovery

The Equinox 3000 is designed to accurately place labels on manually-fed products. Adjustable stops help the operator to position the product. LabelSmart Software provides an intuitive operator interface and environment for label creation.

Options

- Network Interface
- Label Server
- Desktop Label Creation and Management Software
- Different size tampheads

Technical Specifications

Throughput: Up to 1,400 labels/hour

Label Placement

Accuracy: +/- .010" (.254mm)

FACILITY REQUIREMENTS

EQUINOX 3000

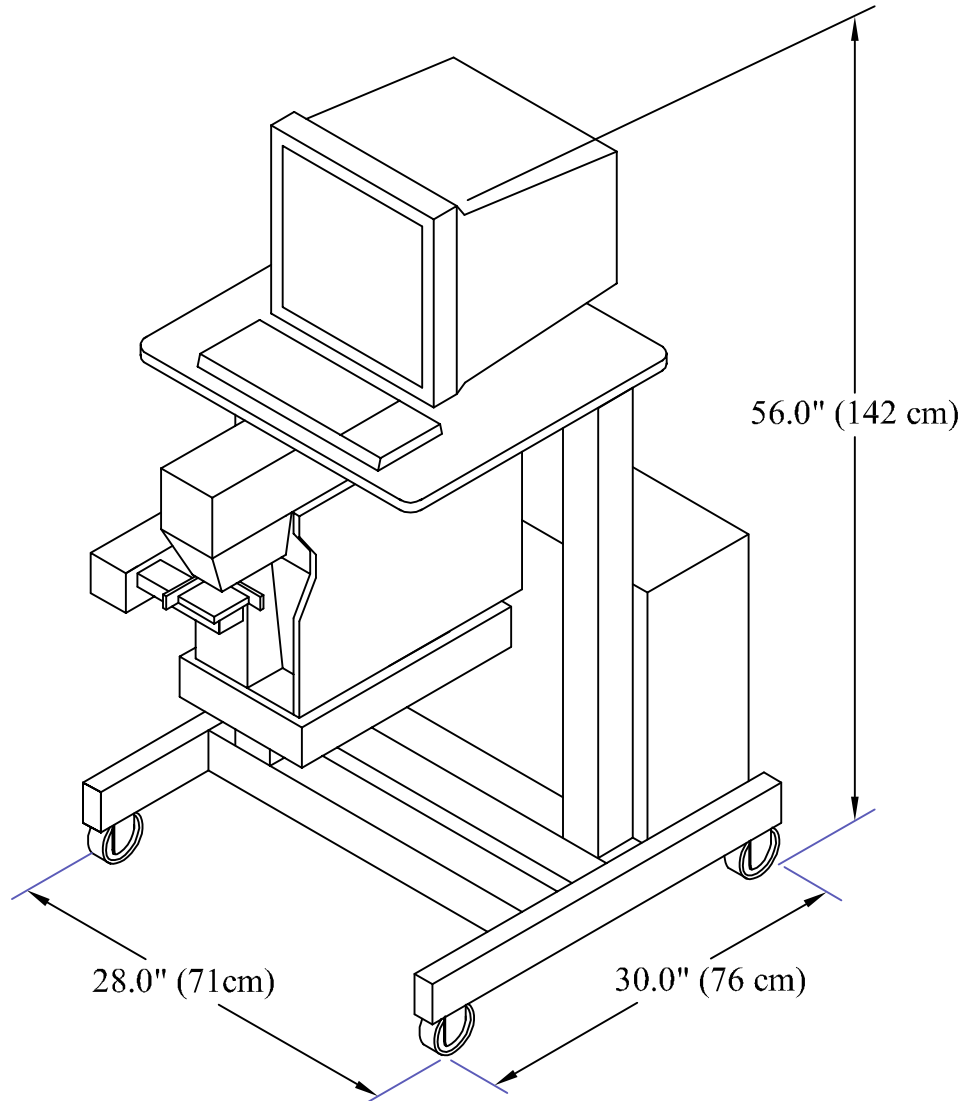

Power: 110/220 VAC, 10 AMP, Single Phase

Air Fitting: ¼" Plug, Industrial Design
Quick Disconnect
(MIL-C-4109)

Air Consumption: 7 SCFM (199 Nl/min)
Clean, dry air @ 100 PSI
(6.9 Bar)

Weight: 250 pounds, 114 kg.

NORTEK AUTOMATION, INC.
www.nortekautomation.com

Copyright (c) 2001
All Rights Reserved